



LORANDI
INDIA

Material Conveying Automation and
STORAGE SILOS

Italian
Design @ 
Indian Price



Lorandi Silos India

"Lorandi Silos India (P) Ltd" is a Joint-Venture between Lorandi Silos, Italy and Penguin Engineers, India, which firmly believes in innovation and customer delight. The knowledge base of the 71 year old Italian company with the technical expertise of Indian partner is a right match to provide state-of-the-art solution in the field of material handling and storage.

We focus our efforts on conveying and handling materials in the best possible way for the product and the process. Our technologies are world class solution for moving materials around the factories in complete safety with economics and with great precision.

Our products and services include:

- **Storage Silos**
- **Blending Silos**
- **Recycling Plants**
- **Material Handling**
- **Silos Loading System**
- **Conveying Automation**
- **Automatic Pallet Debagging**



www.lorandisilos.in



STORING

We innovate our machines and your systems for the current trend and ever changing requirements of our customers. Our storage silos are designed and fabricated in monolithic single piece or sections and finally assembled on site. Our silos are designed according to the correct silo size and geometry, along with the analysis of seismic activity. We make Silos in SS, GI and Aluminium.



Buffer Silos

Buffer Silos for extra light plastic

Hopper and small silo with extract or for plastic film and light milled plastics

Optionals for SILOS

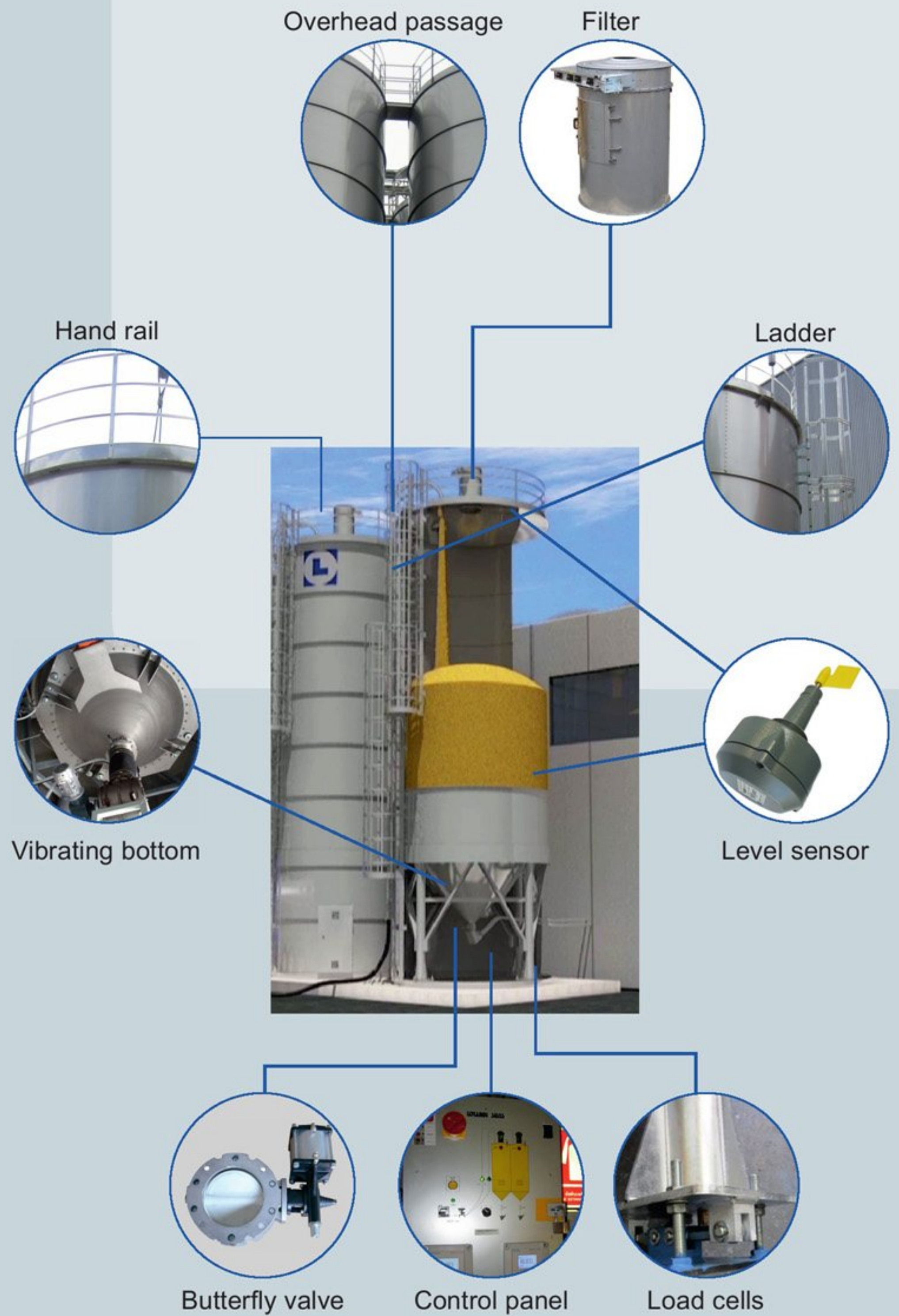

Textile (Fabric) Silos

Textile Silos

- Storing raw materials - powders, granules - chemical, pharmaceutical, plastics & rubber, food, confectionary, bakeries etc.
- Suitable for indoor installations, sheltered from weather
- Equipped with support frames, anti-dust, breathable fabric (to avoid condensation) and filters
- Custom made design according to the building
- Suitable for food stuff, fabric totally made of polyester thread



CONVEYING

An essential component in handling system is safe passage and reliable product conveying from one place to other place. Our systems are designed with robust, state-of-the-art technology with low-maintenance to transfer material. Energy efficient, robust, low maintenance conveying systems, designed to transport materials around your plant safely and efficiently at an adjustable rate that meets the current operational requirements.



SILOS LOADING SYSTEMS



Silos Loading System from Big-bags and Sacks upto 12T/h.
Maximum height: 20 meters



* Transfers upto 4-10 Ton/hr.

ACCESSORIES

Cyclones



Helical super separating cyclones from Ø350 to Ø1800

Rotary Valves



Made in cast iron or in stainless steel



Branches for ventilation and pneumatic conveyors
ø 100 - 160 - 200 - 210 - 270



LH Piping system



Extension for hoppers

Blowers

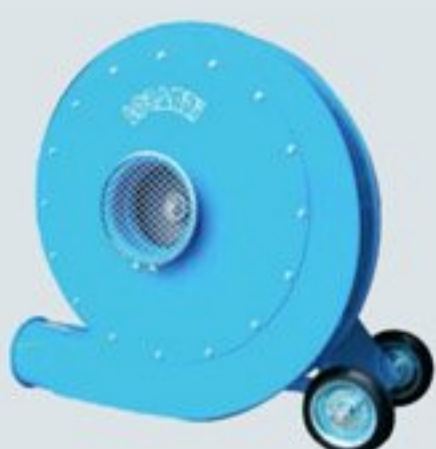

Injectors



Butterfly valve



Pipes



Hoppers





MIXING

Overview of mixers at a factory

Our mixing silos results in good homogenisation of goods such as pellets, flakes, granules. It also helps to drop the temperature of flakes out of the extruder. Various dimensions and capacities with optionals are available for each industry.



Mixers - Heating / Cooling

(Applications to remove humidity or to refresh plastic materials)

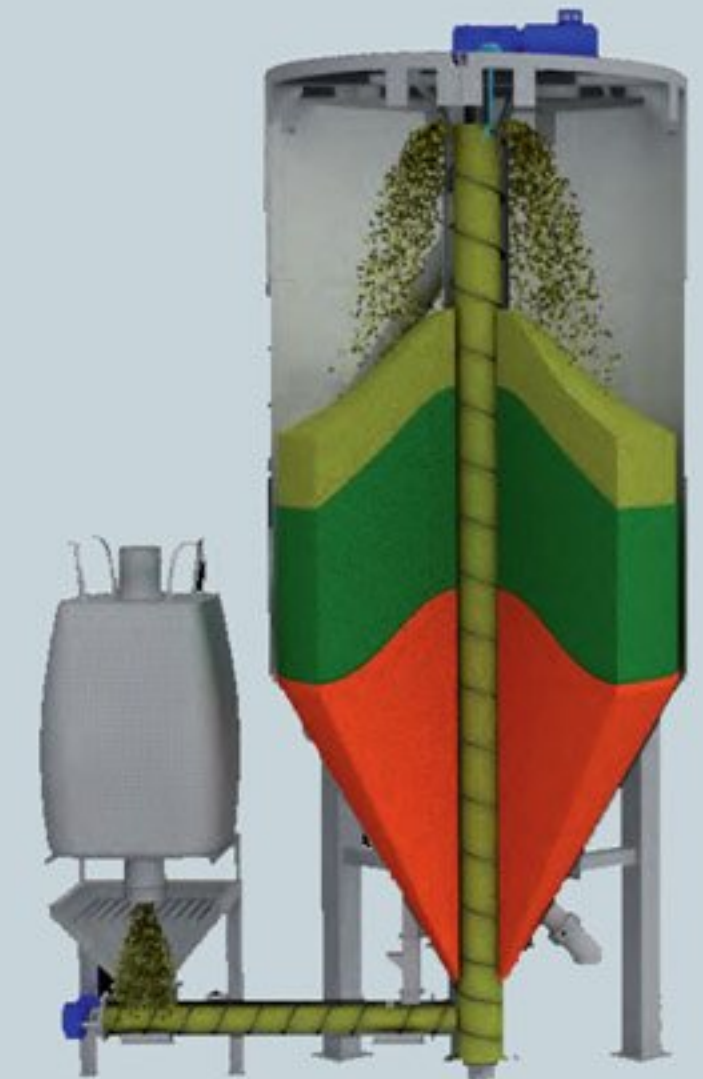
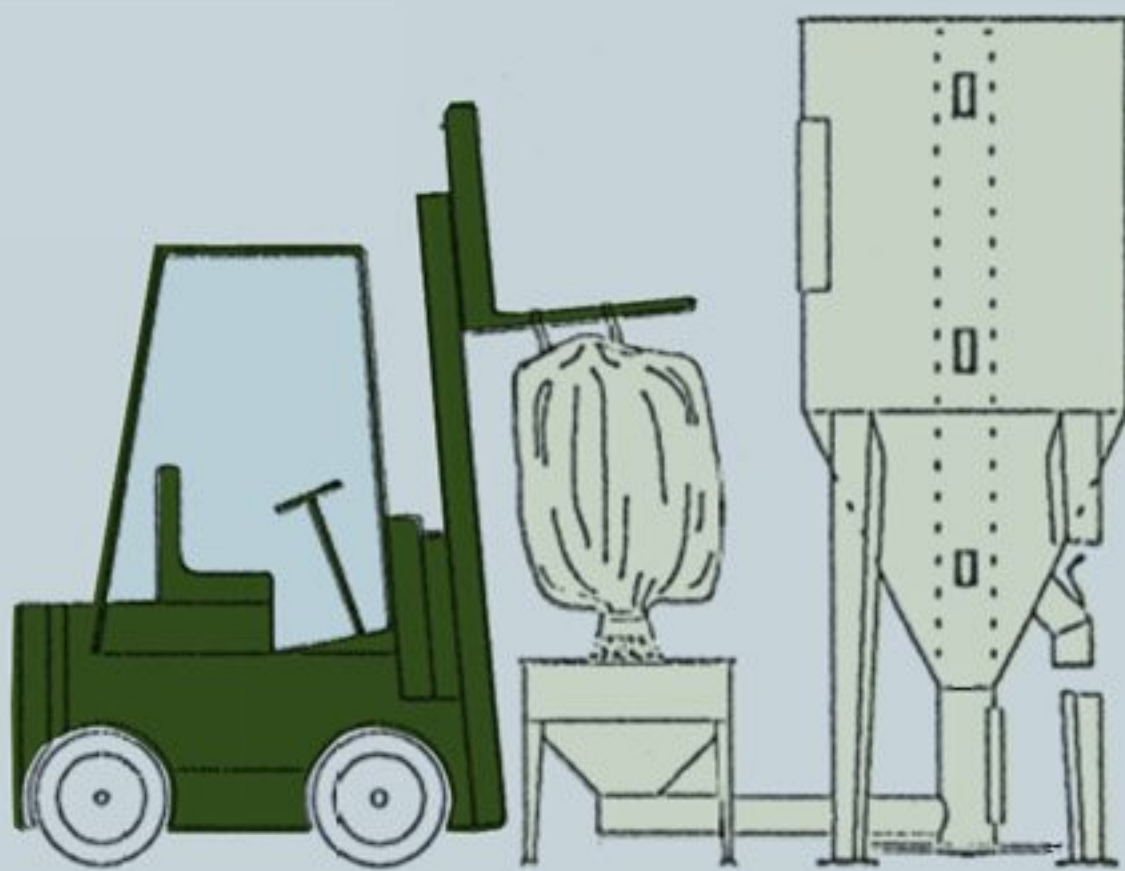

Mixers for plastic materials



Electric control box with weighing scales

Standard



Optional





RECYCLING

From LORANDI's experience and research, we offer a line of products and services entirely dedicated to STORAGE, TREATMENT AND TRANSPORT for the plastics recycling industry. With LORANDI you can create your own customized plant for the storage, separation, mixing, handling and complete management of recycled plastic materials of different types and weights. Experience, know-how and latest-generation technology at your service, to optimize and speed up production, eliminating any criticality.

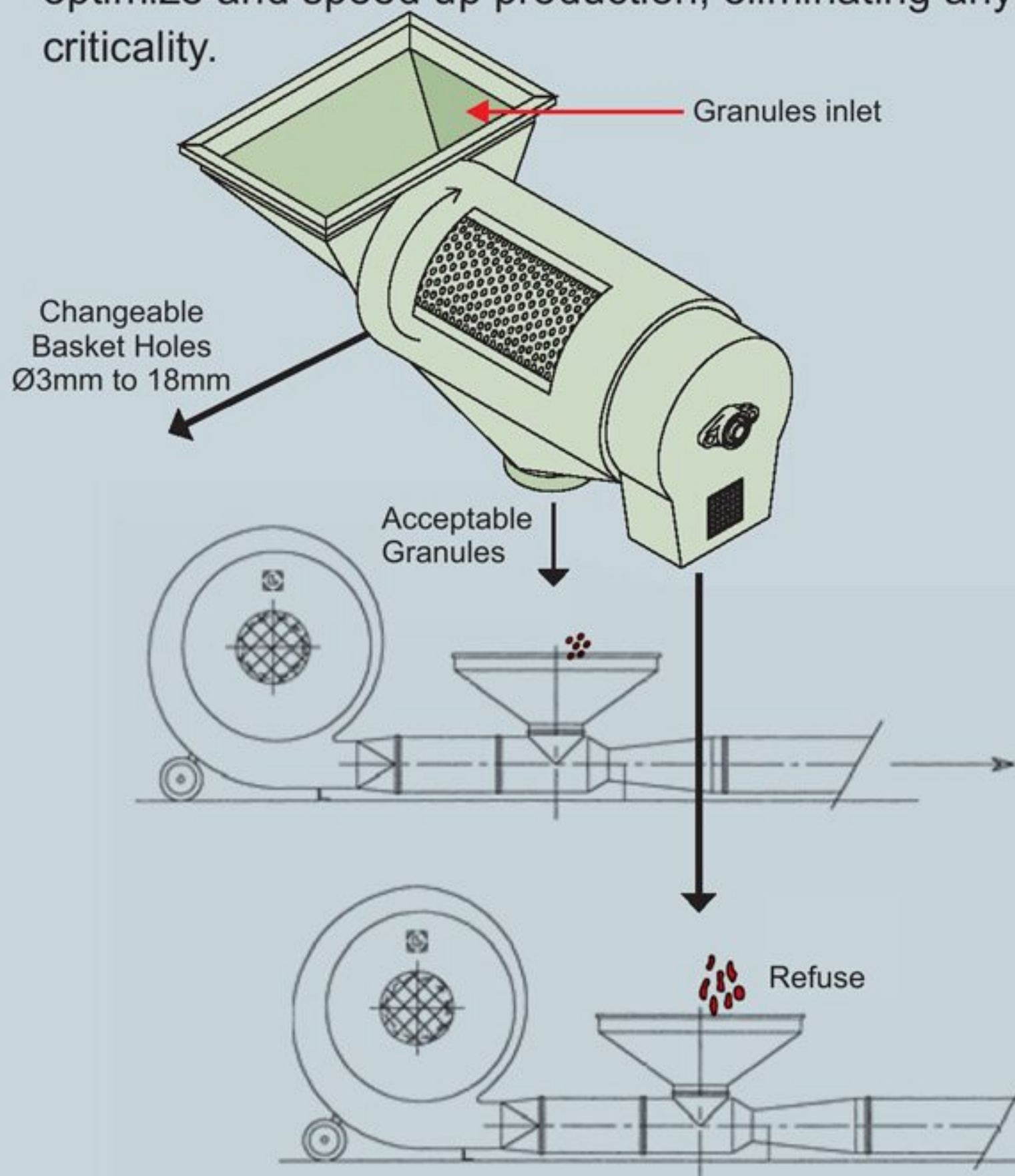

Separation based on size

PET Recycling - Separation of caps & wrappers

Separating System "T-Cleaner" for Granules and Flakes



Separation based on bulk density



Pre-cleaner cleaning system for light parts suction

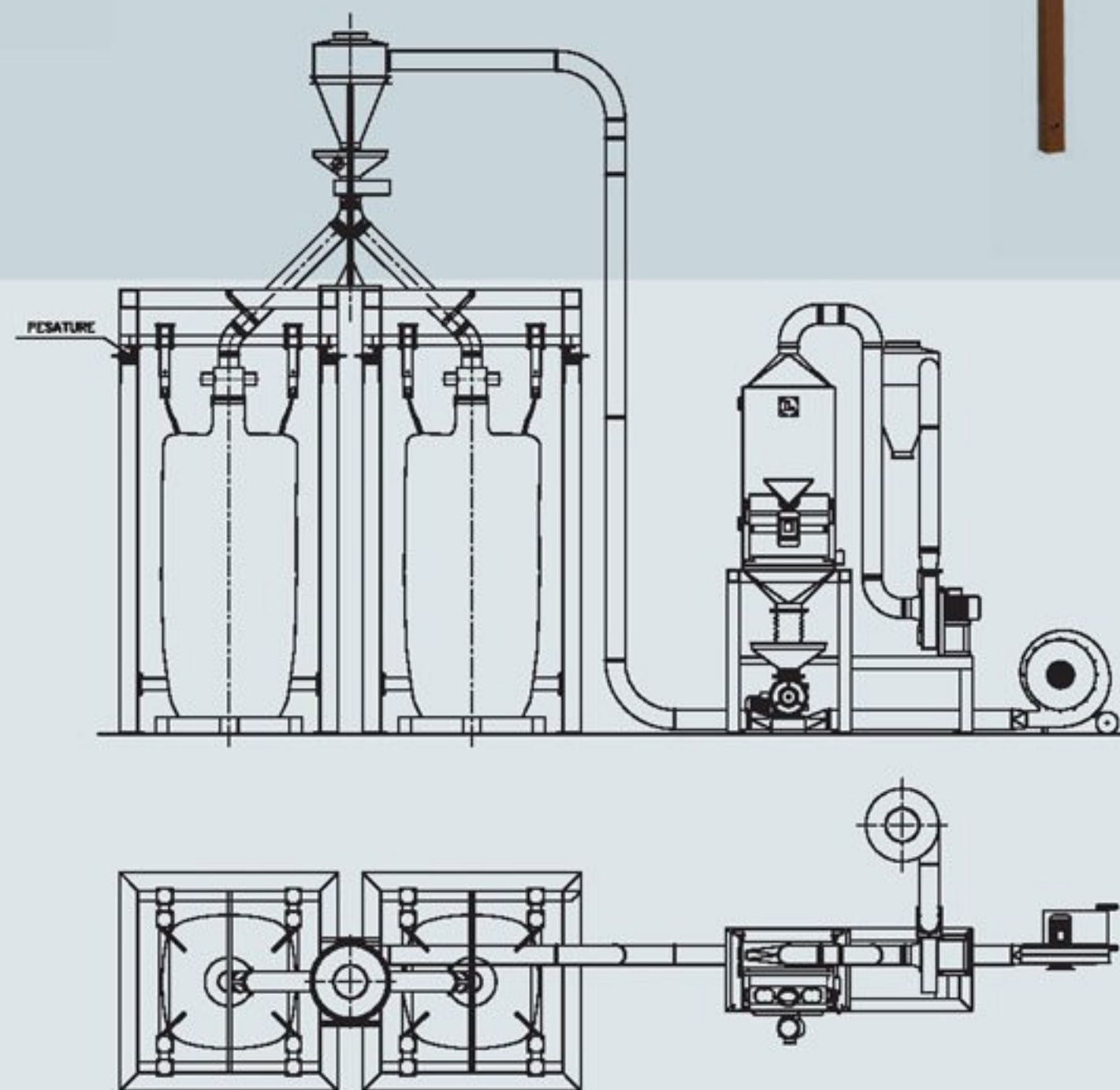

Application examples



HANDLING

Material handling is an art. We solve the pragmatic problems caused by the movement, storage in any handling area. We protect and control the products throughout the processes of cleaning, preparation, distribution etc.

Continuous Weighted System



Compacting system with pistons



Structure for sacks



Screw Conveyors



Big-bags discharge station for flakes, PET, PE, Film, PS scraps complete with discharge ampoule



**Manual bag breaker
Manual bag opener with vibrating cone and screw**



Automatic Pallet De-Bagging

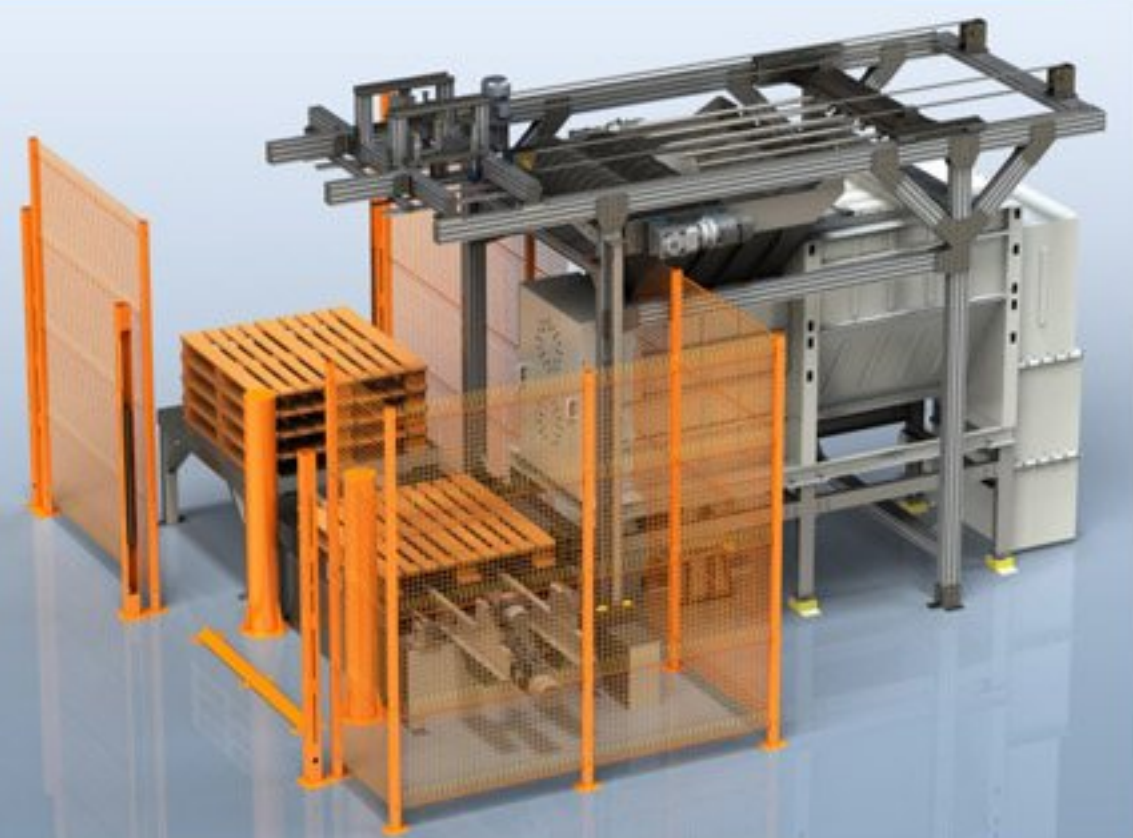

The Factory Building was inaugurated by Consul General of Italy, India



The Machine Shop was inaugurated by Mr. Stefano Lorandi, Lorandi Silos S.r.l. - Italy

LORANDI SILOS INDIA (P) LTD

Works:
S.F.No. 173 / 3A5, Pillaiapampalayam
Kariyampalayam Pirivu, Annur
Coimbatore - 641 653. INDIA
Tel: +91 - 422 - 7140 668

Office:
46-B, KRK Road, Ramanathapuram
Coimbatore - 641 045. INDIA
Tel: +91-422-231 5640/41
Mobile: +91-94433 73641

